

BMC METAL-ARC



METAL LABORATORY SYSTEMS

TABLE OF CONTENTS

Specifications -----	1
Base Cabinets - Standing/Counter Height -----	2 - 8
Base Cabinets - Sink/Fume Hood Standing Height -----	9
Base Cabinets - Special Purpose -----	10
Acid Storage Cabinets -----	11
Flammable Storage Cabinets -----	11
Base Cabinets - Sitting/Desk Height -----	12 - 14
Corner Base Cabinets - Sitting/Desk Height -----	15
Corner Sink Cabinets - Sitting/Desk Height -----	15
Wall Case Units -----	16 - 17
Corner Wall Case Units -----	17
Floor Case Units -----	18 - 19
Fume Hoods -----	20 - 21
Aprons and Drawer Housings -----	22
Utility Tables -----	23
Accessories -----	24 - 25

Cover
Parke-Davis Co.
Holland, MI

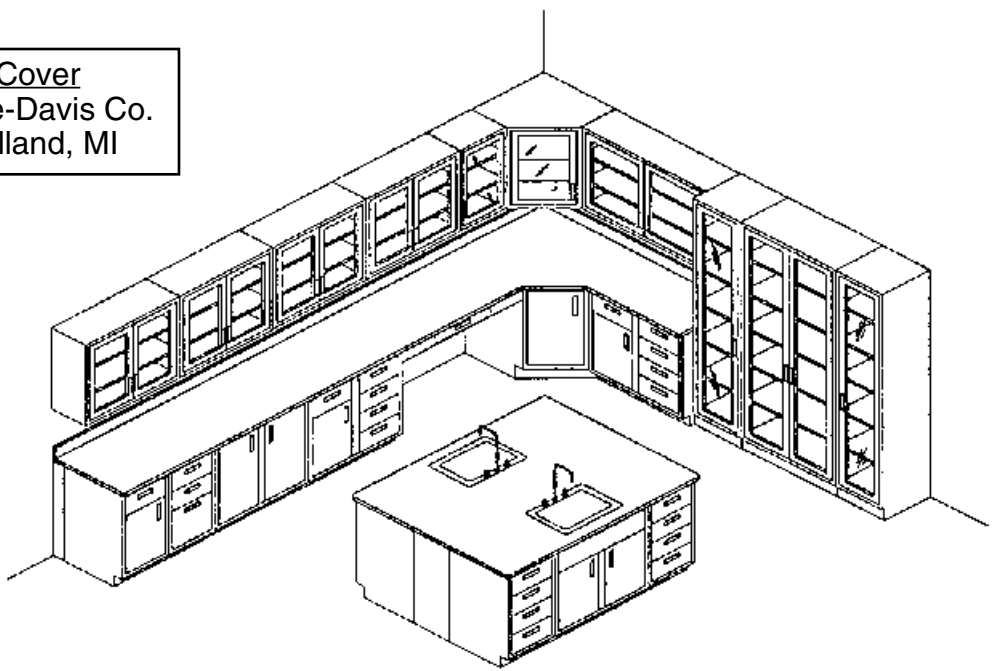

BASE CABINETS *Standing/Counter Height*

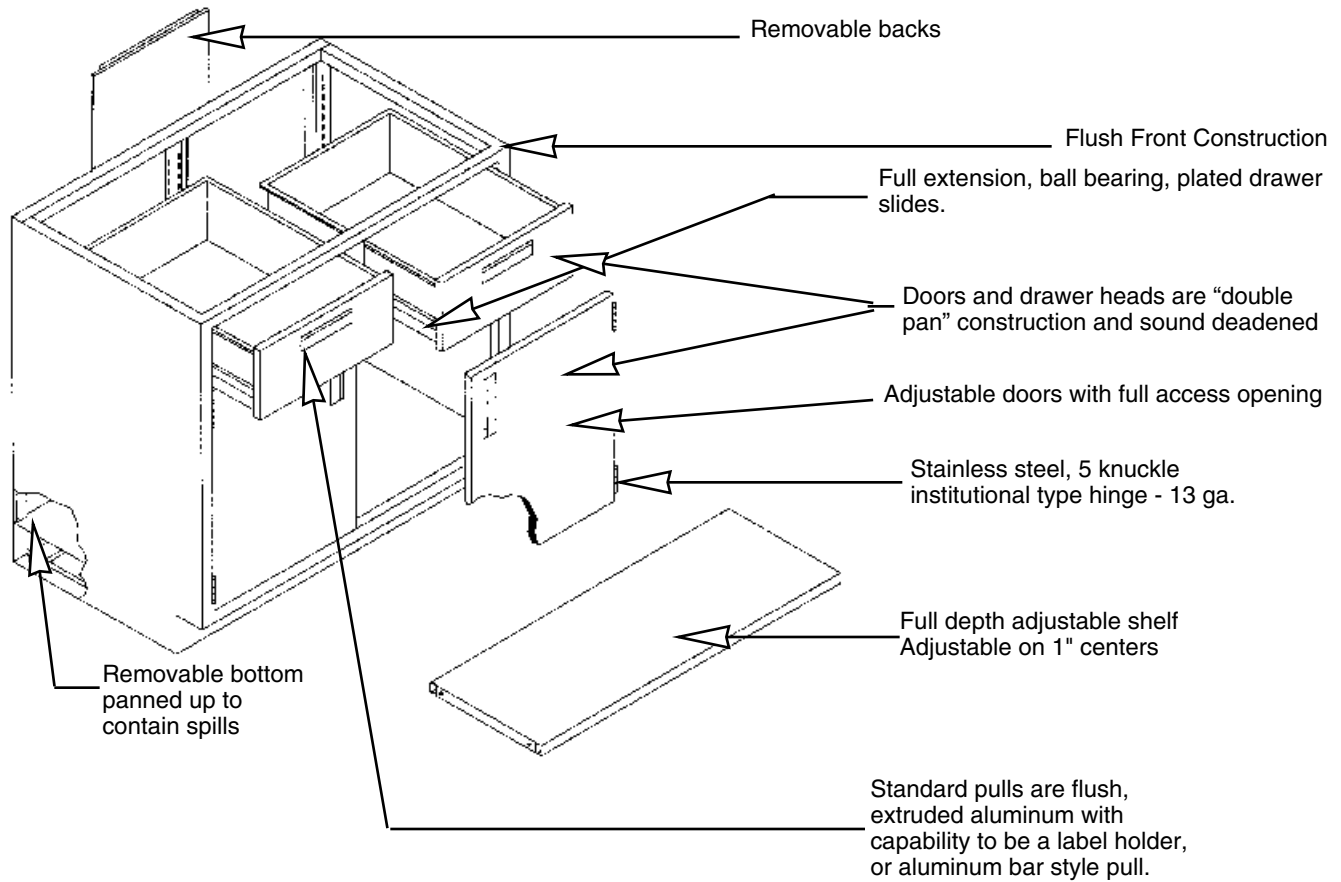

Additional Specifications

All surfaces shall be painted or zinc plated. The paint is a chemical resistant baked on epoxy powder. Specific test data is available upon request.

Gauges of base cabinet components are as follows:

Aprons	18 ga.	Legs - 2" sq. tube	18 ga.
Back Panels	20 ga.	Shelves	18 ga.
Bottom Panels	18 ga.	Side Panels	18 ga.
Drawer/Door Outer Panel	20 ga.	Table Frames	18 ga.
Door Inner Panel	20 ga.	K & V Shelve Clip	
Drawer Bodies	20 ga.		

For complete specifications, request our full line of products specifications.

Subject to change.

BASE CABINETS *Standing/Counter Height*

Standing/Counter Height 35" High x 22" Deep. Units are available in various widths as shown. Drawer units feature full extension slides. A single shelf is standard in the units shown. Additional shelves are available (see page 11). Specify left or right hand doors. Hand is indicated by side of door upon which hinge is located.

Part Numbering System

Sample: B3536-048 1 = Base unit 4 = #Doors
 12233-456 2 = Height 5 = #Drawers
 3 = Width 6 = #Half Drawers

*"F" = File Drawer
 *"S" = Sink Unit
 *"P" = Panel
 *"R" = Right hinge facing cab.
 *"L" = Left hinge facing cab.

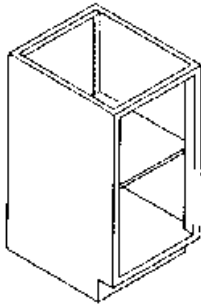
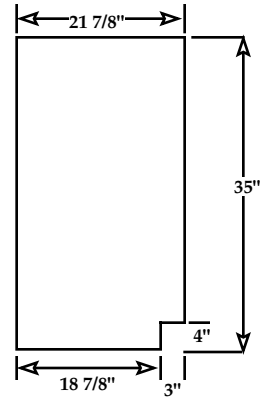

B3515-000
B3518-000
B3524-000

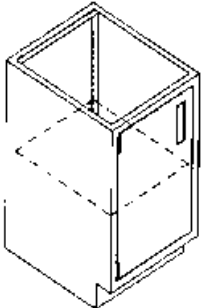

B3515-100(L)
B3518-100(L)
B3524-100(L)

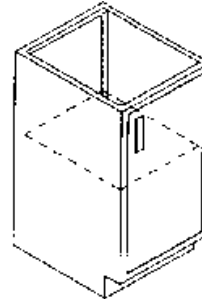

B3515-100(R)
B3518-100(R)
B3524-100(R)

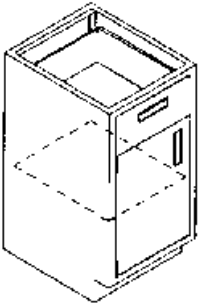

B3515-110(L)
B3518-110(L)
B3524-110(L)

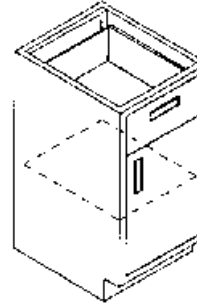

B3515-110(R)
B3518-110(R)
B3524-110(R)

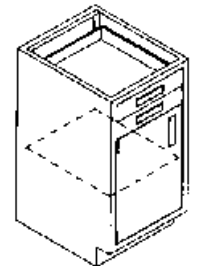

B3515-102(L)
B3518-102(L)
B3524-102(L)

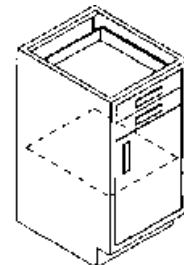

B3515-102(R)
B3518-102(R)
B3524-102(R)

NOTE: When ordering units with configurations that are non-standard, drawings must accompany order.

BASE CABINETS *Standing/Counter Height*

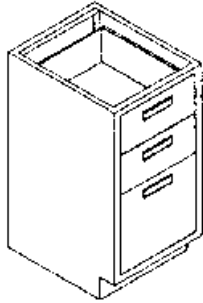

**B3515-F20
B3518-F20
B3524-F20**

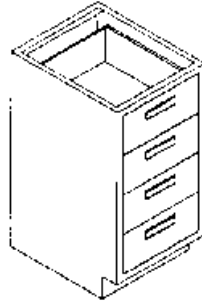

**B3515-040
B3518-040
B3524-040**

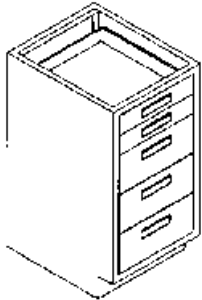

**B3515-032
B3518-032
B3524-032**

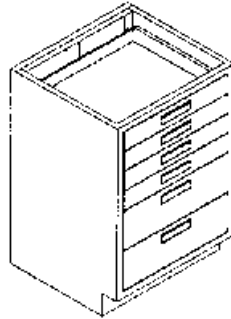

**B3515-024
B3518-024
B3524-024**

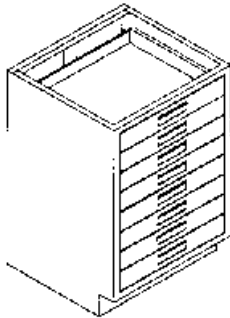

**B3515-008
B3518-008
B3524-008**

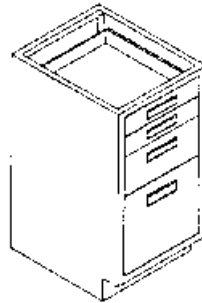

**B3515-F12
B3518-F12
B3524-F12**

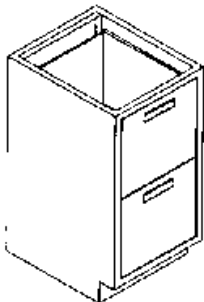

**B3515-FFO
B3518-FFO
B3524-FFO**

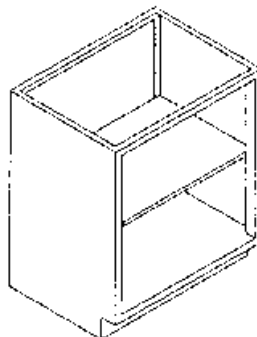

**B3530-000
B3536-000
B3542-000
B3548-000**

B
M
C
/
M
E
T
A
L
-
A
R
C

BASE CABINETS *Standing/Counter Height*

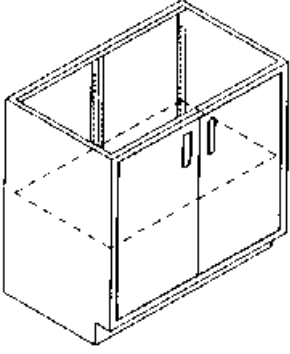

**B3530-200
B3536-200
B3542-200
B3548-200**

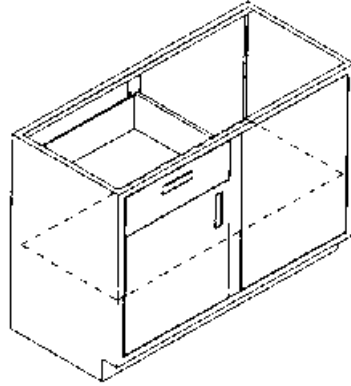

**B3530-110(L)SP
B3536-110(L)SP
B3542-110(L)SP
B3548-110(L)SP**

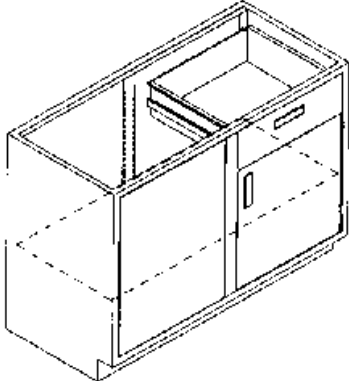

**B3530-110(R)SP
B3536-110(R)SP
B3542-110(R)SP
B3548-110(R)SP**

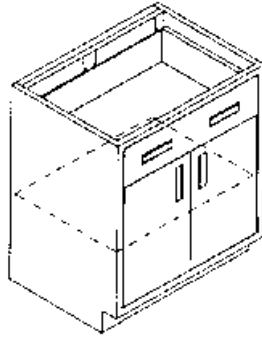

**B3530-210
B3536-210
B3542-210
B3548-210**

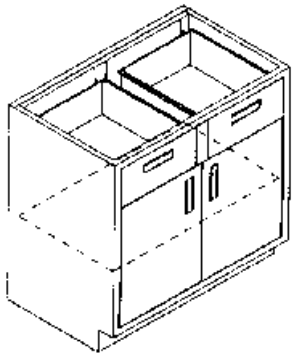

**B3530-220
B3536-220
B3542-220
B3548-220**

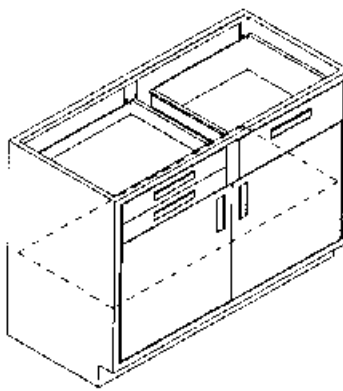

**B3530-212A
B3536-212A
B3542-212A
B3548-212A**

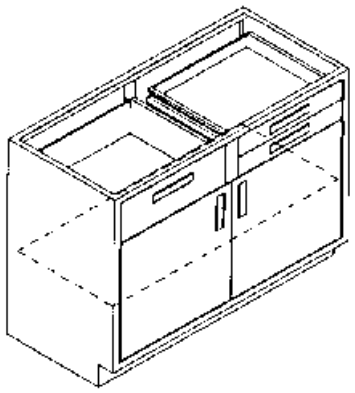

**B3530-212B
B3536-212B
B3542-212B
B3548-212B**

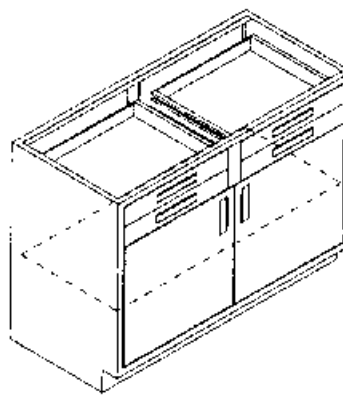

**B3530-204
B3536-204
B3542-204
B3548-204**

BASE CABINETS *Standing/Counter Height*

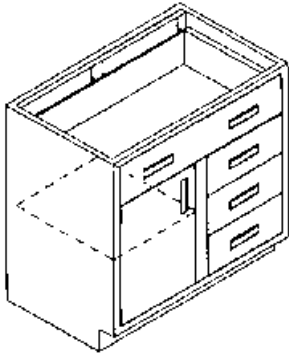

B3530-140B(L)
B3536-140B(L)
B3542-140B(L)
B3548-140B(L)

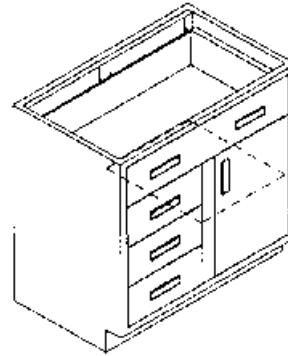

B3530-140B(R)
B3536-140B(R)
B3542-140B(R)
B3548-140B(R)

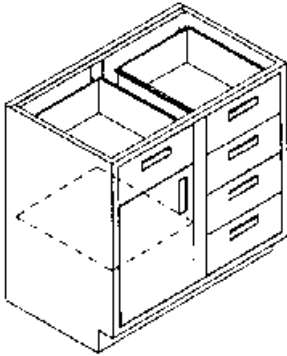

B3530-150(L)
B3536-150(L)
B3542-150(L)
B3548-150(L)

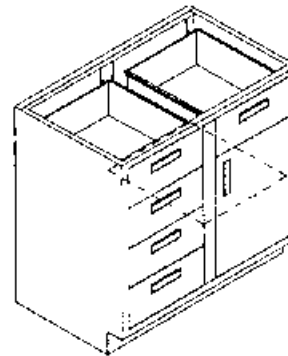

B3530-150(R)
B3536-150(R)
B3542-150(R)
B3548-150(R)

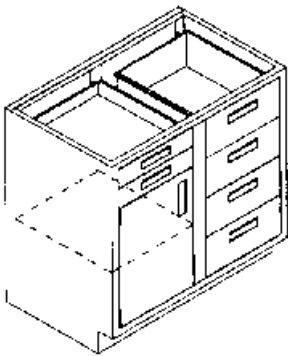

B3530-142(L)
B3536-142(L)
B3542-142(L)
B3548-142(L)

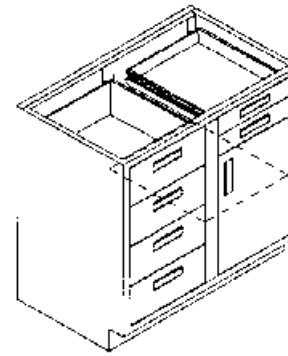

B3530-142(R)
B3536-142(R)
B3542-142(R)
B3548-142(R)

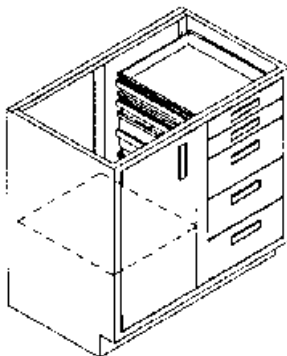

B3530-132(L)
B3536-132(L)
B3542-132(L)
B3548-132(L)

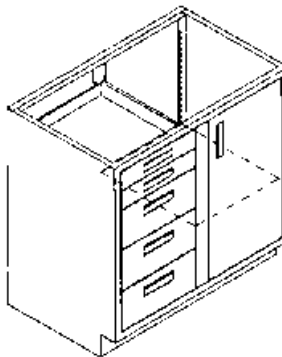

B3530-132(R)
B3536-132(R)
B3542-132(R)
B3548-132(R)

B
M
C
/
M
E
T
A
L
-
A
R
C

BASE CABINETS *Standing/Counter Height*

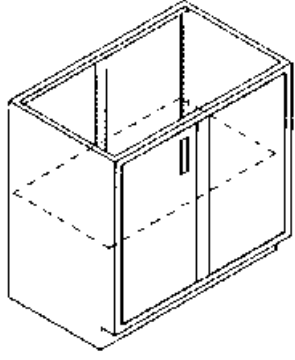

**B3530-100(L)SP
B3536-100(L)SP
B3542-100(L)SP
B3548-100(L)SP**

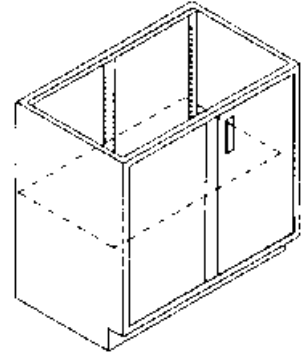

**B3530-100(R)SP
B3536-100(R)SP
B3542-100(R)SP
B3548-100(R)SP**

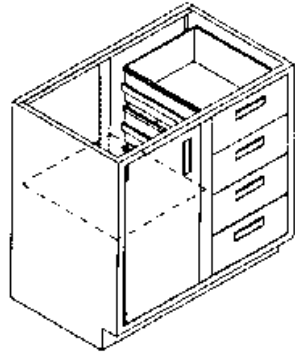

**B3530-140A(L)
B3536-140A(L)
B3542-140A(L)
B3548-140A(L)**

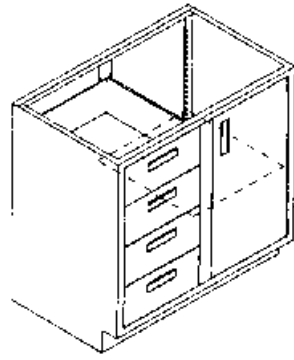

**B3530-140A(R)
B3536-140A(R)
B3542-140A(R)
B3548-140A(R)**

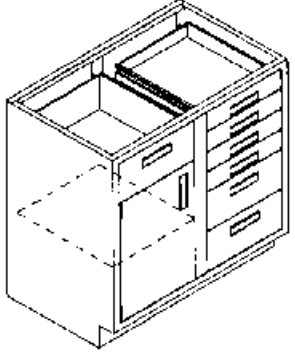

**B3530-134(L)
B3536-134(L)
B3542-134(L)
B3548-134(L)**

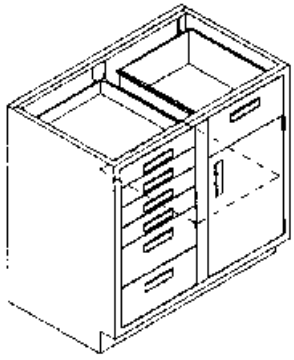

**B3530-134(R)
B3536-134(R)
B3542-134(R)
B3548-134(R)**

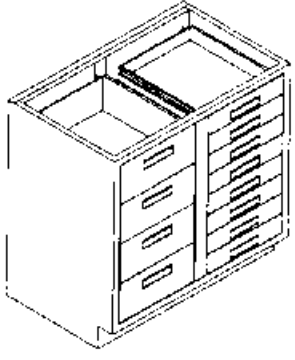

**B3530-048A
B3536-048A
B3542-048A
B3548-048A**

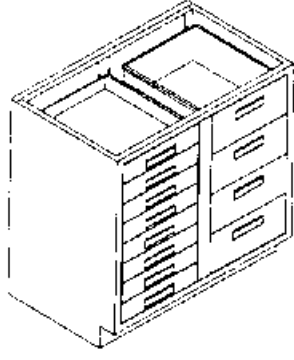

**B3530-048B
B3536-048B
B3542-048B
B3548-048B**

NOTE: When ordering units with configurations that are non-standard, drawings must accompany order.

BASE CABINETS *Standing/Counter Height*

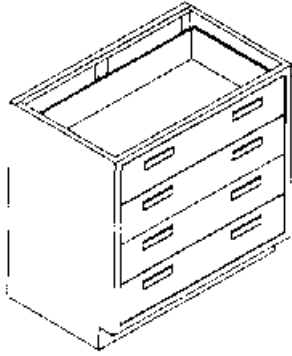

**B3530-040
B3536-040
B3542-040
B3548-040**

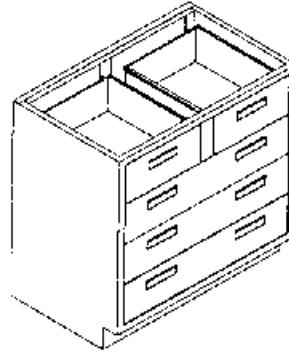

**B3530-050
B3536-050
B3542-050
B3548-050**

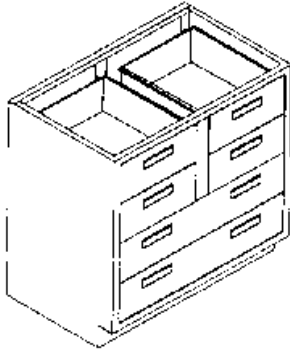

**B3530-060
B3536-060
B3542-060
B3548-060**

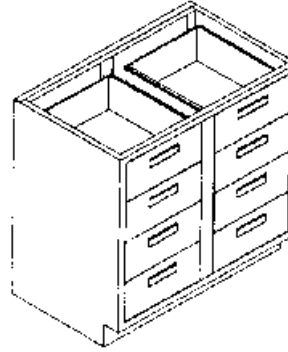

**B3530-080
B3536-080
B3542-080
B3548-080**

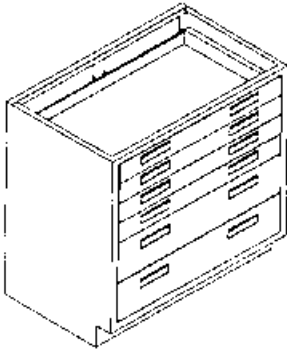

**B3530-024
B3536-024
B3542-024
B3548-024**

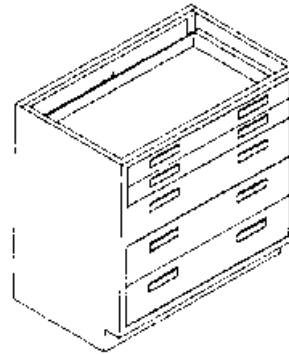

**B3530-032
B3536-032
B3542-032
B3548-032**

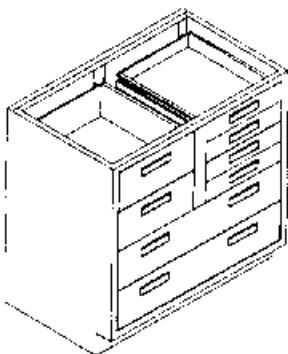

**B3530-044A
B3536-044A
B3542-044A
B3548-044A**

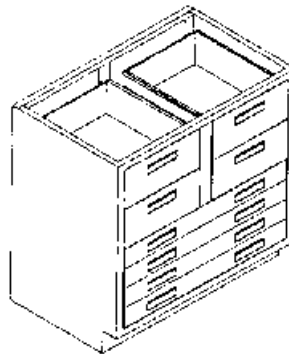

**B3530-044B
B3536-044B
B3542-044B
B3548-044B**

B M C / M E T A L - A R C

BASE CABINETS *Standing/Counter Height*

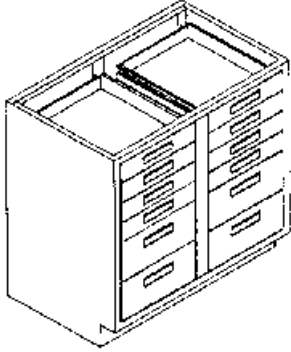

**B3530-048C
B3536-048C
B3542-048C
B3548-048C**

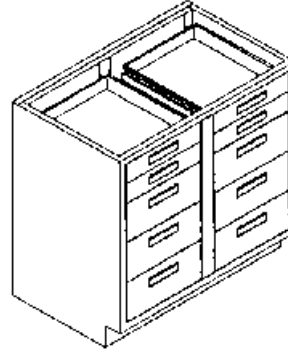

**B3530-064
B3536-064
B3542-064
B3548-064**

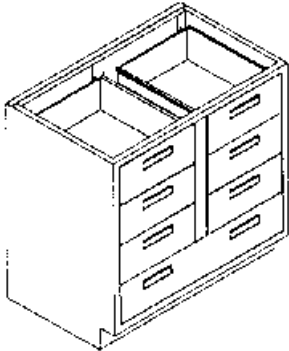

**B3530-070A
B3536-070A
B3542-070A
B3548-070A**

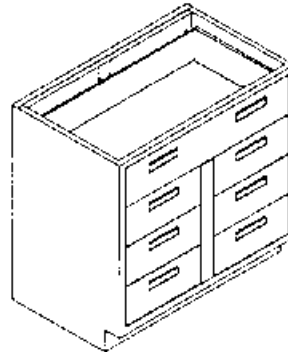

**B3530-070B
B3536-070B
B3542-070B
B3548-070B**

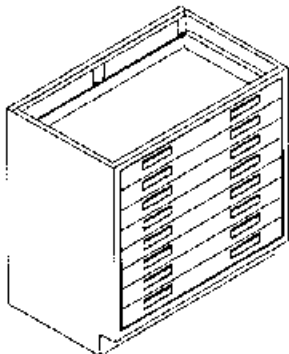

**B3530-008
B3536-008
B3542-008
B3548-008**

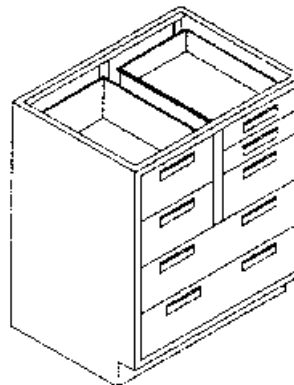

**B3530-052
B3536-052
B3542-052
B3548-052**

NOTE: When ordering units with configurations that are non-standard, drawings must accompany order.

SINK AND FUME HOOD BASE CABINETS *Stand Up Height*

ALSO AVAILABLE IN SITTING/DESK HEIGHT

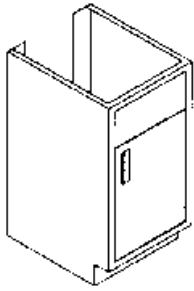

Sink Base
B3518-10S(R)
B3524-10S(R)

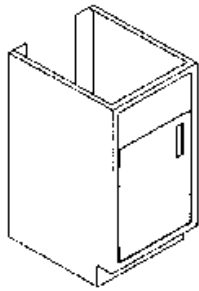

Sink Base
B3518-10S(L)
B3524-10S(L)

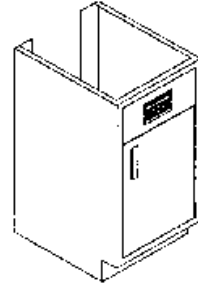

Sink Base
B3518-10S(R)
Louvered
B3524-10S(R)
Louvered

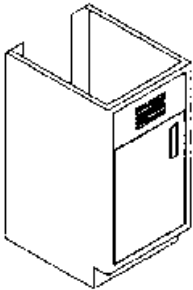

Sink Base
B3518-10S(L)
Louvered
B3524-10S(L)
Louvered

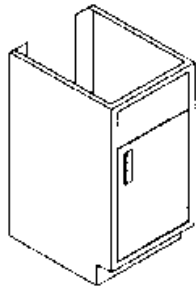

Hood Base
B3518-10P(R)
B3524-10P(R)

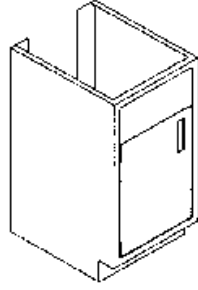

Hood Base
B3518-10P(L)
B3524-10P(L)

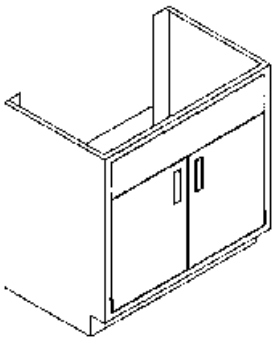

Sink Base
B3530-20S
B3536-20S
B3542-20S
B3548-20S
B3552-20S
B3558-20S

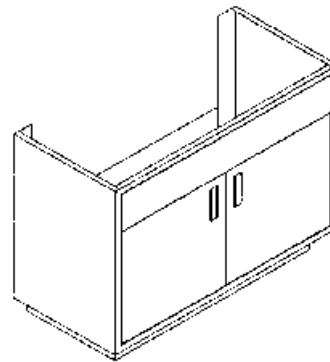

Sink Island Base
B3552-20SI
B3558-20SI

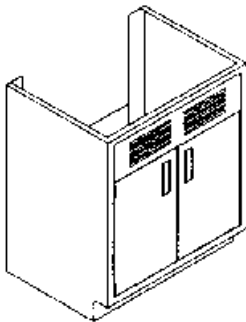

Sink Base
B3530-20S Louvered
B3536-20S Louvered
B3542-20S Louvered
B3548-20S Louvered
B3552-20S Louvered
B3558-20S Louvered

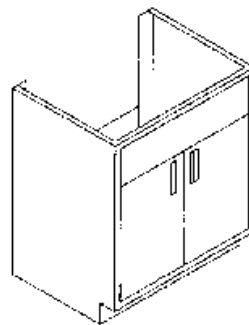

Hood Base
B3530-20P
B3536-20P
B3542-20P
B3548-20P
B3552-20P
B3558-20P

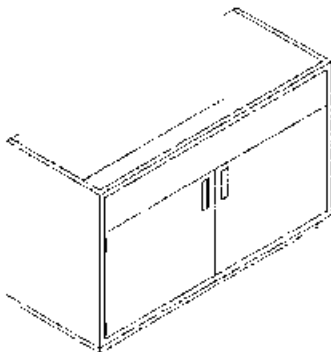

Hood Island Base
B3552-20PI
B3558-20PI

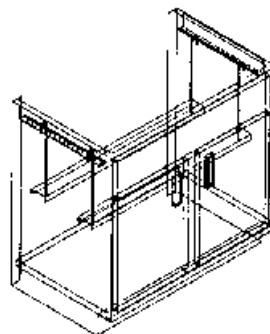

Sink Support Assembly
SS-36
SS-C14 SS-48
SS-18 SS-42
SS-24 SS-52
SS-30 SS-58

C
A
R
L
L
A
B
O
R
A
T
O
R
Y
S
Y
S
T
E
M
S

BASE CABINETS *Special Purpose Bases*

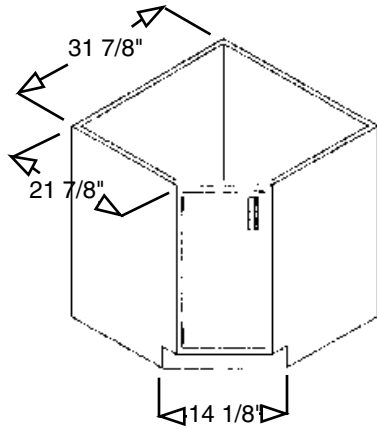

Typical Dimensions

C3514-100(L)

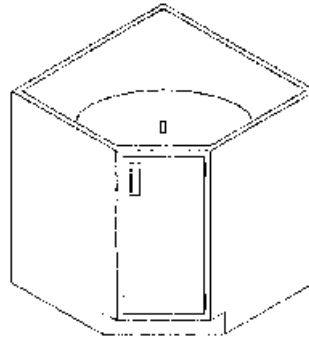

C3514-100(R)
*(SHOWN WITH
OPTIONAL LAZY
SUSAN INSTALLED)*

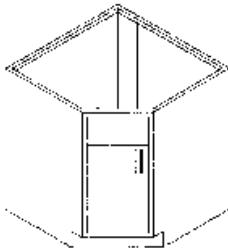

C3514-10S(L)

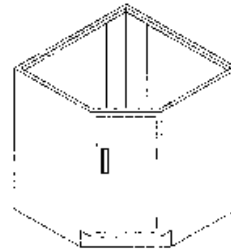

C3514-10S(R)

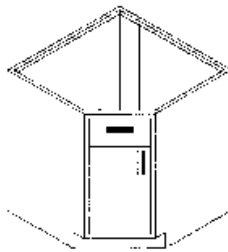

C3514-10S(L)
Louvered

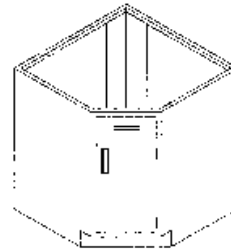

C3514-10S(R)
Louvered

MOBILE BASES

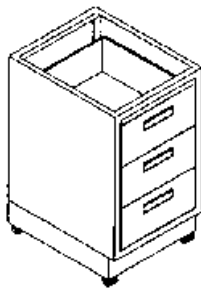

MB2915-030
MB2918-030
MB2924-030
MB2930-030



MB3515-040
MB3518-040
MB3524-040
MB3530-040

ACID STORAGE CABINET

Metal-Arc Acid Storage Cabinets are steel reinforced polyethylene lined to reduce the possibilities of corrosion. Note: All Acid Cabinets are 18" deep.

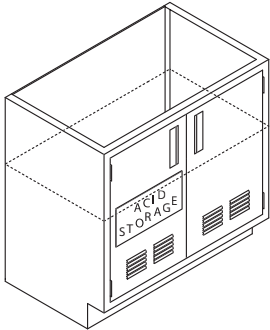

ASB2918-10P	ASB3518-10P	} 1 Door Units
ASB2924-10P	ASB3524-10P	
ASB2930-20P	ASB3530-20P	
ASB2936-20P	ASB3536-20P	
ASB2942-20P	ASB3542-20P	
ASB2948-20P	ASB3548-20P	
ASB2952-20P	ASB3552-20P	
ASB2958-20P	ASB3558-20P	

Add Suffix "VK" if Vent Kit is Required

FLAMMABLE STORAGE CABINET

Note: All Flammable Cabinets are 18" deep.

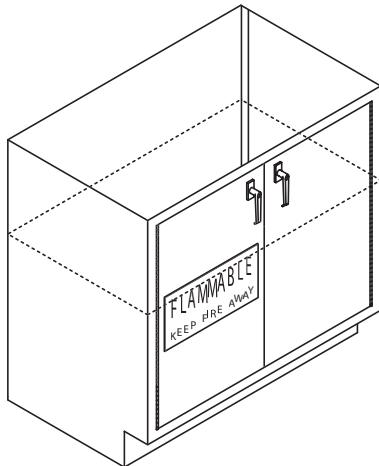

FSB2924-100	FSB3524-100	} 1 Door Units
FSB2930-200	FSB3530-200	
FSB2936-200	FSB3536-200	
FSB2942-200	FSB3542-200	
FSB2948-200	FSB3548-200	
FSB2952-200	FSB3552-200	
FSB2958-200	FSB3558-200	

STANDARD SHELF

Standard base cabinet shelf with brackets. Available for 29" and 35" units.

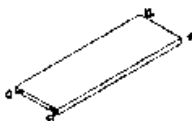

BS15
BS18
BS21
BS24
BS30
BS36
BS42
BS48

PULL-OUT SHELF

Optional pull-out shelf for base cabinets. Shelf is full extension with ball bearing slides. *Note: Cabinet door must be open 90 deg. to allow for extension.



BPS15
BPS18
BPS21
BPS24
BPS30
BPS36
BPS42
BPS48

NOTE: When ordering units with configurations that are non-standard, drawings must accompany order.

BASE CABINETS *Sitting/Desk Height*

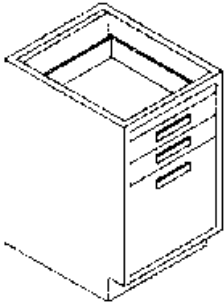

**B2915-F02
B2918-F02
B2924-F02**

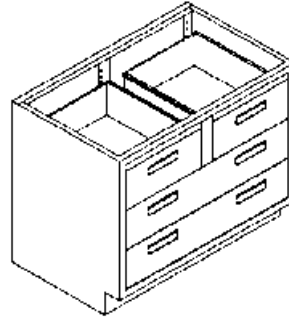

**B2930-040
B2936-040
B2942-040
B2948-040**

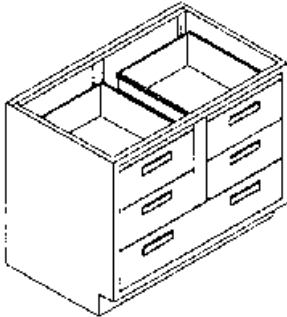

**B2930-050
B2936-050
B2942-050
B2948-050**

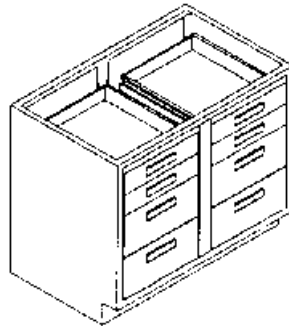

**B2930-044
B2936-044
B2942-044
B2948-044**

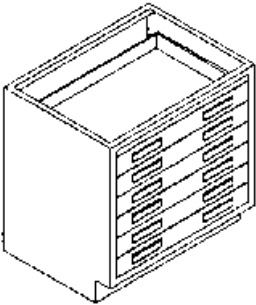

**B2930-006
B2936-006
B2942-006
B2948-006**

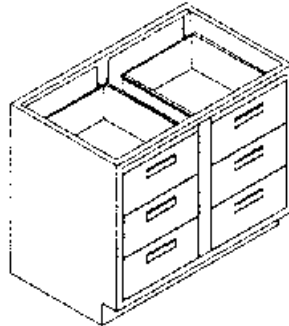

**B2930-060
B2936-060
B2942-060
B2948-060**

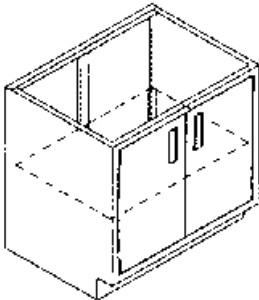

**B2930-200
B2936-200
B2942-200
B2948-200**

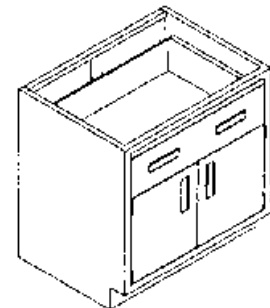

**B2930-210
B2936-210
B2942-210
B2948-210**

B M C / M E T A L - A R C

BASE CABINETS *Sitting/Desk Height*

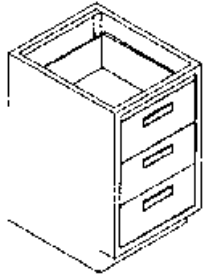

**B2915-030
B2918-030
B2924-030**

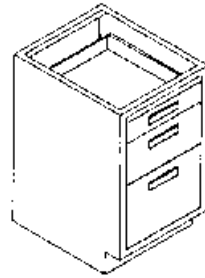

**B2915-B11
B2918-B11
B2924-B11**

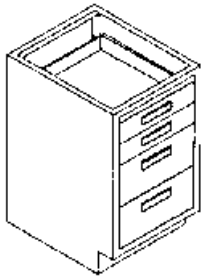

**B2915-022
B2918-022
B2924-022**

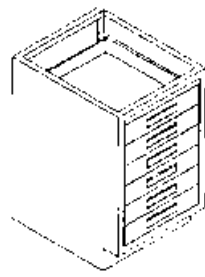

**B2915-006
B2918-006
B2924-006**

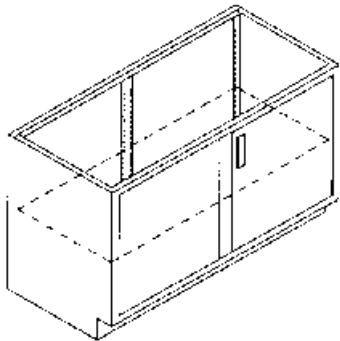

**B2930-100(RorL)SP
B2936-100(RorL)SP
B2942-100(RorL)SP
B2948-100(RorL)SP**

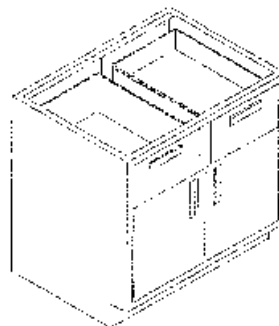

**B2930-220
B2936-220
B2942-220
B2948-220**

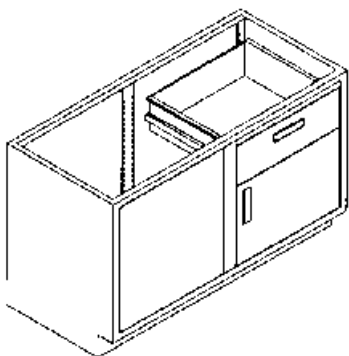

**B2930-110(R)SP
B2936-110(R)SP
B2942-110(R)SP
B2948-110(R)SP**

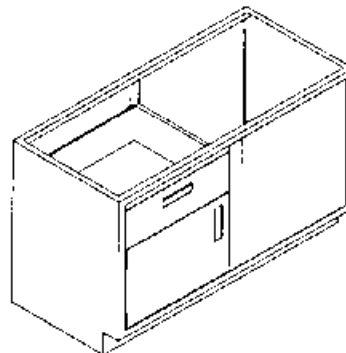

**B2930-110(L)SP
B2936-110(L)SP
B2942-110(L)SP
B2948-110(L)SP**

CORNER BASE CABINET *Sitting/Desk Height*

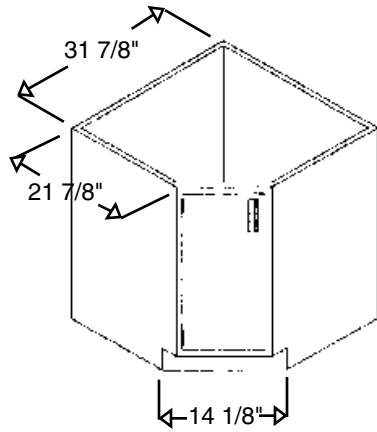

Typical Dimensions

C2914-100(L)

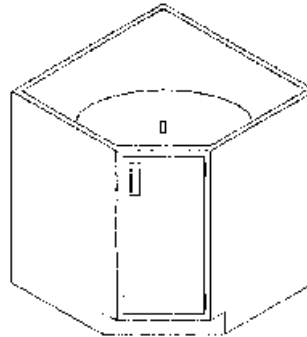

C2914-100(R)

(SHOWN WITH OPTIONAL LAZY SUSAN INSTALLED)

CORNER SINK BASE CABINETS *Sitting/Desk Height*

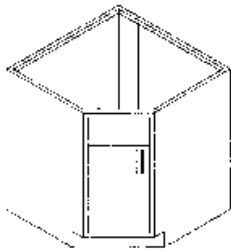

C2914-10S(L)

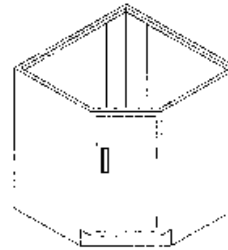

C2914-10S(R)

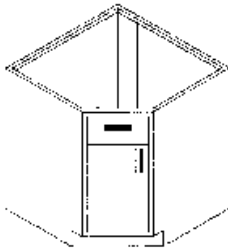

**C2914-10S(L)
Louvered**

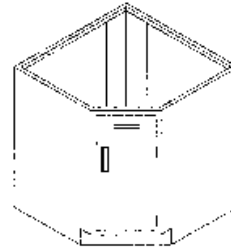

**C2914-10S(R)
Louvered**

OPTIONAL LAZY SUSAN *(For corner base cabinets)*

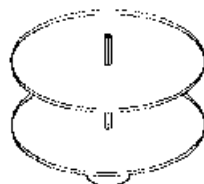

**LS-29
LS-35**

WALL CASE UNITS

Wall cases are available in sizes ranging from 24", 31", 36" and 48" high and 18" wide to 48" wide. All units are 13" deep as standard. 24" high units have one shelf. 31" high to 36" high units have two shelves. 48" high units have three shelves. Additional shelves are available. On single hinge door units, specify (R) or (L) hinge. 48" high units have 3 hinges per door.

Part Numbering System

Sample: W3036-2GS 1= Wall Case 4= #Doors
 12233-4567 2= Height 5= Material of doors*
 3= Width 6= Type of doors* *
 * Steel, Glass or no doors (open) 7= Depth Note: 13" dp. standard,
 * * Hinged, Sliding or Sliding/framed 16" deep cabinets available -
 * "R" = Right hinge facing cabinet indicate by final suffix of 16,
 * "L" = Left hinge facing cabinet (Example: **W2418-00016**)

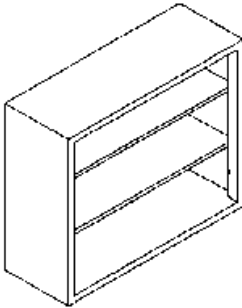

W2418-000	W3018-000	W3618-000	W4818-000
W2424-000	W3024-000	W3624-000	W4824-000
W2430-000	W3030-000	W3630-000	W4830-000
W2436-000	W3036-000	W3636-000	W4836-000
W2442-000	W3042-000	W3642-000	W4842-000
W2448-000	W3048-000	W3648-000	W4848-000

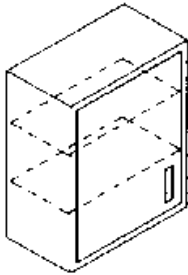

W2418-1SH(L)
 W3018-1SH(L)
 W3618-1SH(L)
 W4818-1SH(L)
 W2424-1SH(L)
 W3024-1SH(L)
 W3624-1SH(L)
 W4824-1SH(L)

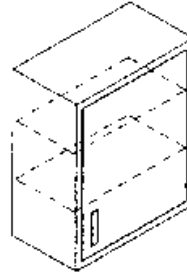

W2418-1SH(R)
 W3018-1SH(R)
 W3618-1SH(R)
 W4818-1SH(R)
 W2424-1SH(R)
 W3024-1SH(R)
 W3624-1SH(R)
 W4824-1SH(R)

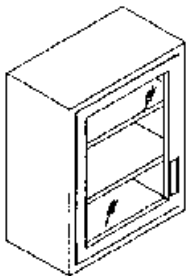

W2418-1GH(L)
 W3018-1GH(L)
 W3618-1GH(L)
 W4818-1GH(L)
 W2424-1GH(L)
 W3024-1GH(L)
 W3624-1GH(L)
 W4824-1GH(L)

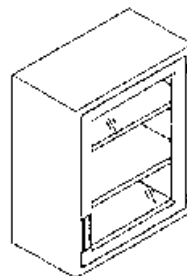

W2418-1GH(R)
 W3018-1GH(R)
 W3618-1GH(R)
 W4818-1GH(R)
 W2424-1GH(R)
 W3024-1GH(R)
 W3624-1GH(R)
 W4824-1GH(R)

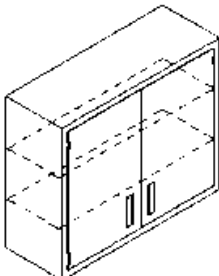

W2430-2SH	W3630-2SH
W2436-2SH	W3636-2SH
W2442-2SH	W3642-2SH
W2448-2SH	W3648-2SH
W3030-2SH	W4830-2SH
W3036-2SH	W4836-2SH
W3042-2SH	W4842-2SH
W3048-2SH	W4848-2SH

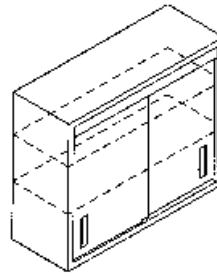

W2430-2SS	W3630-2SS
W2436-2SS	W3636-2SS
W2442-2SS	W3642-2SS
W2448-2SS	W3648-2SS
W3030-2SS	W4830-2SS
W3036-2SS	W4836-2SS
W3042-2SS	W4842-2SS
W3048-2SS	W4848-2SS

NOTE: When ordering units with configurations that are non-standard, **drawings must accompany order.**

WALL CASE UNITS

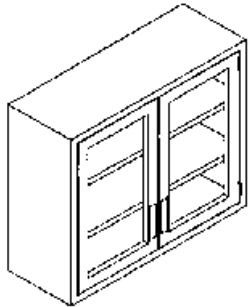

W2430-2GH W3630-2GH
 W2436-2GH W3636-2GH
 W2442-2GH W3642-2GH
 W2448-2GH W3648-2GH
 W3030-2GH W4830-2GH
 W3036-2GH W4836-2GH
 W3042-2GH W4842-2GH
 W3048-2GH W4848-2GH

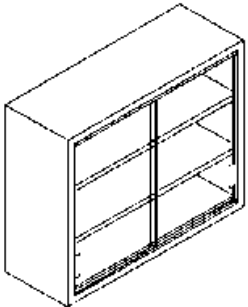

W2430-2GS W3630-2GS
 W2436-2GS W3636-2GS
 W2442-2GS W3642-2GS
 W2448-2GS W3648-2GS
 W3030-2GS W4830-2GS
 W3036-2GS W4836-2GS
 W3042-2GS W4842-2GS
 W3048-2GS W4848-2GS

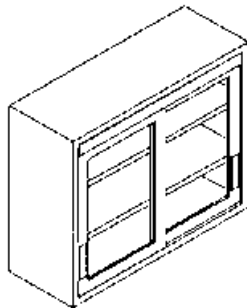

W2430-2GSF W3630-2GSF
 W2436-2GSF W3636-2GSF
 W2442-2GSF W3642-2GSF
 W2448-2GSF W3648-2GSF
 W3030-2GSF W4830-2GSF
 W3036-2GSF W4836-2GSF
 W3042-2GSF W4842-2GSF
 W3048-2GSF W4848-2GSF

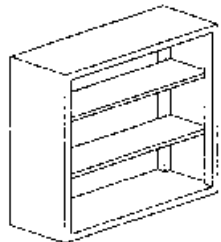

WDS3030-00013 open-2-s
 WDS3036-00013 open-2-s
 WDS3048-00013 open-2-s

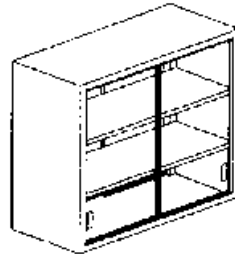

WDS3036-4GS13 open-2-s
 WDS3048-4GS13 open-2-s

CORNER WALL CASE UNITS

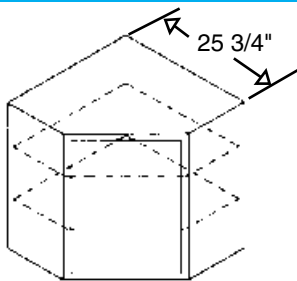

WC3018-000
 WC3618-000

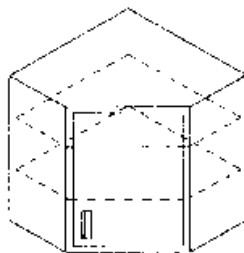

WC3018-1SH(RorL)
 WC3618-1SH(RorL)

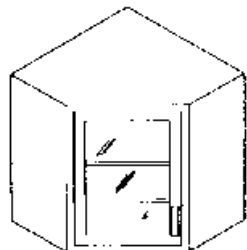

WC3018-1GH(L)
 WC3618-1GH(L)

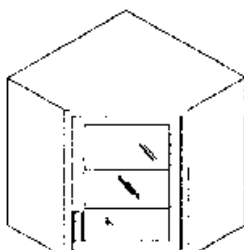

WC3018-1GH(R)
 WC3618-1GH(R)

NOTE: When ordering units with configurations that are non-standard, drawings must accompany order.

FLOOR CASE UNITS

Floor cases are available in widths ranging from 18" to 48". All units are 84" high and are available in either 16" or 21 1/4" depths. Five shelves are standard equipment. Additional shelves are available. On single hinge door units, specify (R) or (L) hinge.

Part Numbering System

Sample: F8418-2SS16 1= Floor Case 4= #Doors
 12233-456 2= Height 5= Material of doors*
 3= Width 6= Type of doors**
 7= Depth

- * Steel Glass or no doors (open)
- ** Hinged, Sliding or Sliding/framed
- * "R" = Right hinge facing cabinet
- * "L" = Left hinge facing cabinet

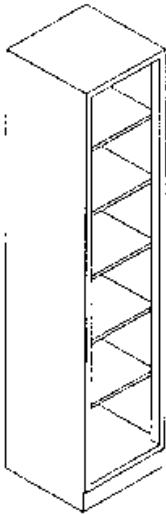

F8418-00016
 F8418-00021
 F8424-00016
 F8424-00021

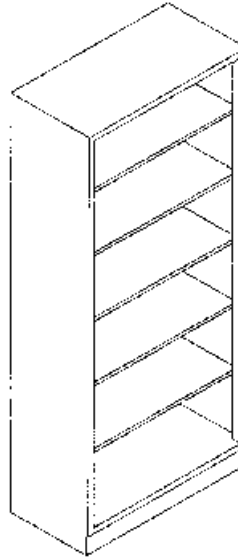

F8430-00016
 F8430-00021
 F8436-00016
 F8436-00021
 F8442-00016
 F8442-00021
 F8448-00016
 F8448-00021

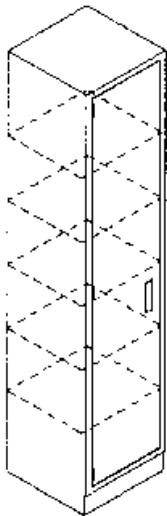

F8418-1SH16(L)
 F8418-1SH21(L)
 F8424-1SH16(L)
 F8424-1SH21(L)

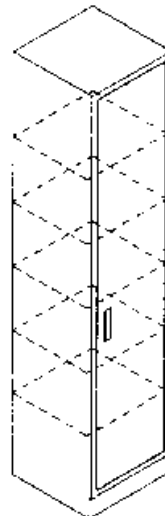

F8418-1SH16(R)
 F8418-1SH21(R)
 F8424-1SH16(R)
 F8424-1SH21(R)

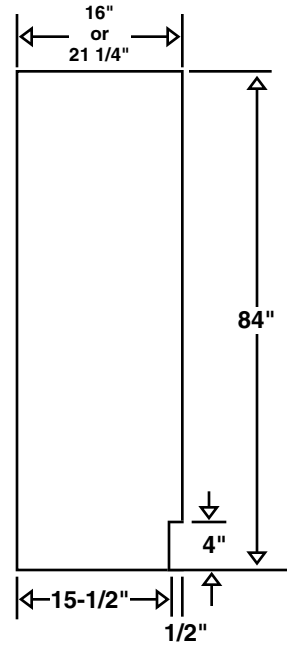

End View (16" Dp. Unit)

NOTE: When ordering units with configurations that are non-standard, drawings must accompany order.

FLOOR CASE UNITS

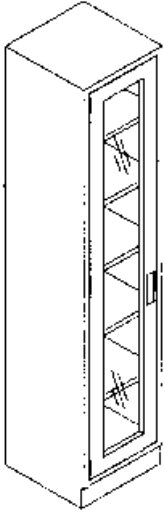

F8418-1GH16(L)
 F8418-1GH21(L)
 F8424-1GH16(L)
 F8424-1GH21(L)

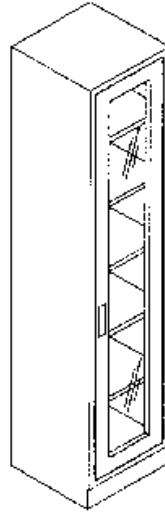

F8418-1GH16(R)
 F8418-1GH21(R)
 F8424-1GH16(R)
 F8424-1GH21(R)

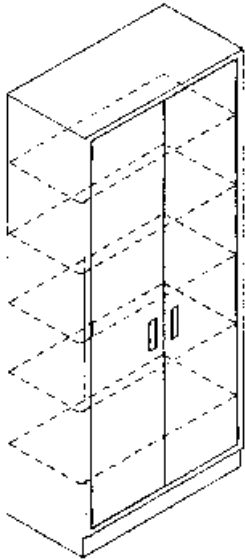

F8430-2SH16
 F8430-2SH21
 F8436-2SH16
 F8436-2SH21
 F8442-2SH16
 F8442-2SH21
 F8448-2SH16
 F8448-2SH21

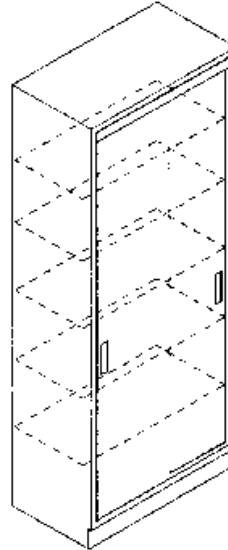

F8430-2SS16
 F8430-2SS21
 F8436-2SS16
 F8436-2SS21
 F8442-2SS16
 F8442-2SS21
 F8448-2SS16
 F8448-2SS21

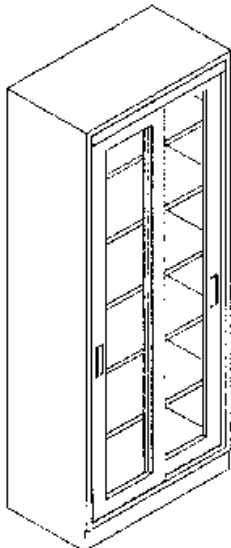

F8430-2GSF16
 F8430-2GSF21
 F8436-2GSF16
 F8436-2GSF21
 F8442-2GSF16
 F8442-2GSF21
 F8448-2GSF16
 F8448-2GSF21

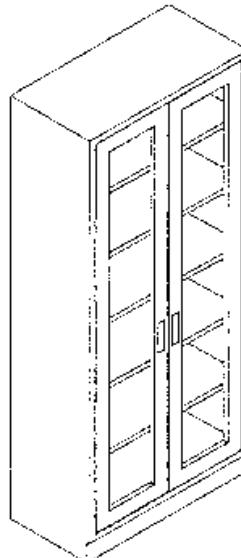

F8430-2GH16
 F8430-2GH21
 F8436-2GH16
 F8436-2GH21
 F8442-2GH16
 F8442-2GH21
 F8448-2GH16
 F8448-2GH21

NOTE: When ordering units with configurations that are non-standard, drawings must accompany order.

FUME HOODS

The name BMC has long been synonymous with quality and longevity. Our newly redesigned fume hood line is a proud example of this reputation. Over 50 years of experience combined with state of the art engineering, manufacturing and testing facilities provide you with a fume hood unsurpassed in quality and performance.

DESIGN

The design of our fume hood line is founded on three basic principals: safety, flexibility and aesthetics.

SAFETY

Safety should be the number one concern when choosing a fume hood. That is why our hoods are tested and certified in accordance with the Ashrae method of testing performance of laboratory fume hoods.

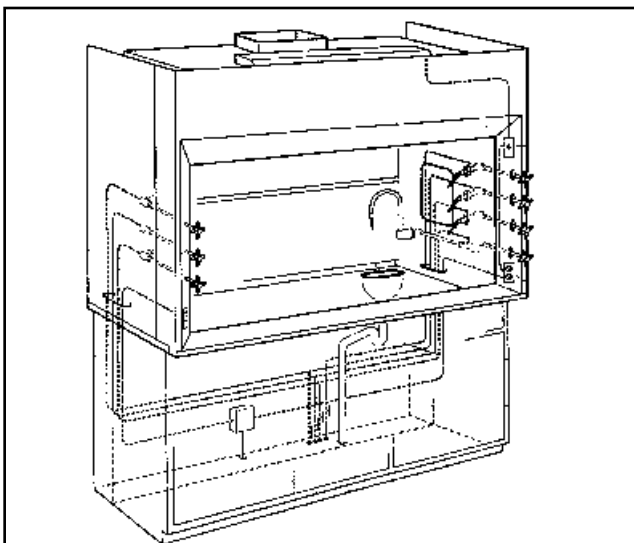

FLEXIBILITY

Construction of our fume hood begins with a heavy duty internal framework. This universal framework is the foundation for a variety of standard and optional features.

These features include. . .

- Chemical resistant interiors of resin-chem, PVC or stainless steel
- PVC or stainless sash guides
- Vertical, horizontal or combination sashes in a variety of materials
- Easy access for service fixture installation
- Manual or remote baffle adjustment
- Fluorescent light fixture
- Optional factory installation of service fixtures

The flexibility of our design will allow you to select standard options that will meet the requirements of your application.

AESTHETICS

Our quality, pride and craftsmanship will insure that your BMC Fume Hood will be a handsome center piece in your laboratory for years to come.

CATALOG

For a complete fume hood catalog contact your local BMC/Metal Arc representative or contact us direct at the following address:

BMC/METAL ARC
P.O. Box 4089
Muskegon, MI 49444
PH: (231) 733-1206
Fax: (231) 733-2116

FUME HOODS

**BYPASS & VARIABLE
AIR VOLUME (VAV)
FUME HOODS**

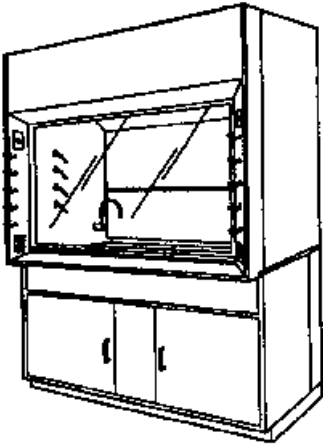
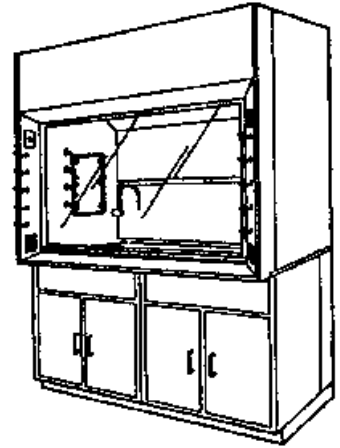

**PERCHLORIC ACID AND
RADIO-ISOTOPE FUME HOODS**

ADA FUME HOODS

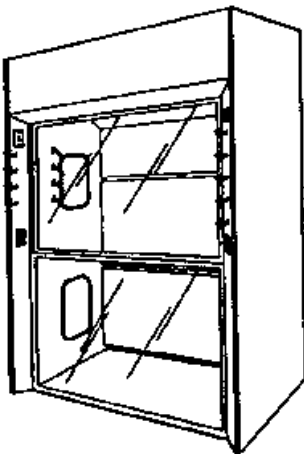
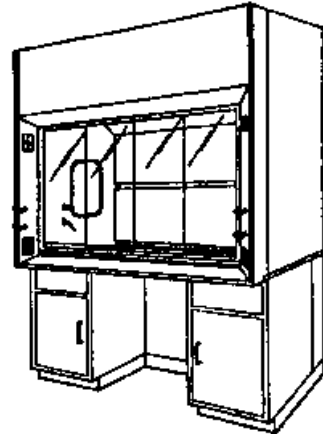

**WALK-IN AND SPECIAL
FUME HOODS**

APRONS AND DRAWER HOUSINGS

Part Numbering System: A046022-000 1= Apron 4= Depth
 1223344-555 2= Height 5= # Drawers
 3= Width

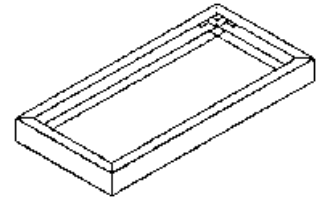

- | | |
|-------------|-------------|
| A042422-000 | A042428-000 |
| A043022-000 | A043028-000 |
| A043622-000 | A043628-000 |
| A044222-000 | A044228-000 |
| A044822-000 | A044828-000 |
| A045422-000 | A045428-000 |
| A046022-000 | A046028-000 |
| A046622-000 | A046628-000 |
| A047222-000 | A047228-000 |

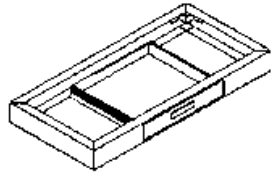

- | | |
|-------------|-------------|
| A042422-001 | A042428-001 |
| A043022-001 | A043028-001 |
| A043622-001 | A043628-001 |
| A044222-001 | A044228-001 |

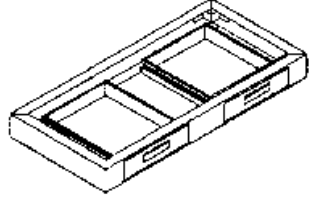

- | | |
|-------------|-------------|
| A044222-002 | A044228-002 |
| A044822-002 | A044828-002 |
| A045422-002 | A045428-002 |
| A046022-002 | A046028-002 |
| A046622-002 | A046628-002 |
| A047222-002 | A047228-002 |

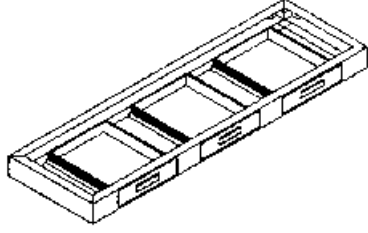

- | | |
|-------------|-------------|
| A047222-003 | A047228-003 |
|-------------|-------------|

Note: Apron heights are 4 1/2" high.

KNEE SPACE RAILS



- | | |
|---------|---------|
| KSR0418 | KSR0452 |
| KSR0424 | KSR0454 |
| KSR0430 | KSR0460 |
| KSR0436 | KSR0466 |
| KSR0442 | KSR0472 |
| KSR0448 | KSR0484 |
| | KSR0496 |

NOTE: When ordering units with configurations that are non-standard, drawings must accompany order.

UTILITY TABLES AND COMPONENTS

29" HIGH TABLES

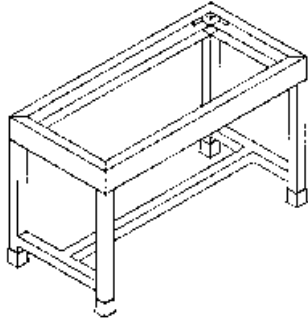

22" DEEP

UT292422-000
 UT293022-000
 UT293622-000
 UT294222-000
 UT294822-000
 UT296022-000
 UT297222-000

28" DEEP

UT292428-000
 UT293028-000
 UT293628-000
 UT294228-000
 UT294828-000
 UT296028-000
 UT297228-000

35" HIGH TABLES

22" DEEP

UT352422-000
 UT353022-000
 UT353622-000
 UT354222-000
 UT354822-000
 UT356022-000
 UT357222-000

28" DEEP

UT352428-000
 UT353028-000
 UT353628-000
 UT354228-000
 UT354828-000
 UT356028-000
 UT357228-000

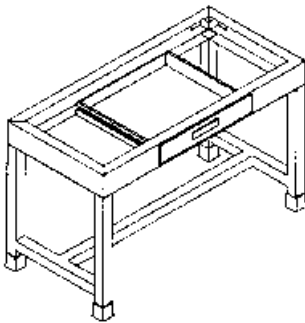

22" DEEP

UT292422-001
 UT293022-001
 UT293622-001
 UT294222-001

28" DEEP

UT292428-001
 UT293028-001
 UT293628-001
 UT294228-001

22" DEEP

UT352422-001
 UT353022-001
 UT353622-001
 UT354222-001

28" DEEP

UT352428-001
 UT353028-001
 UT353628-001
 UT354228-001

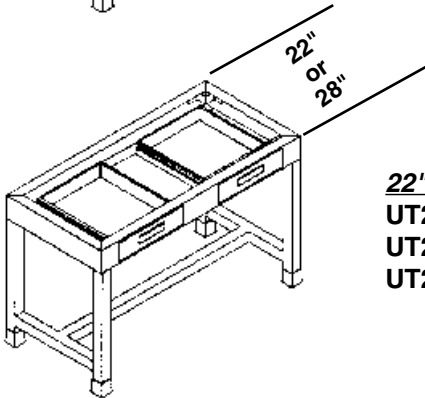

22" DEEP

UT294822-002
 UT296022-002
 UT297222-002

28" DEEP

UT294828-002
 UT296028-002
 UT297228-002

22" DEEP

UT354822-002
 UT356022-002
 UT357222-002

28" DEEP

UT354828-002
 UT356028-002
 UT357228-002

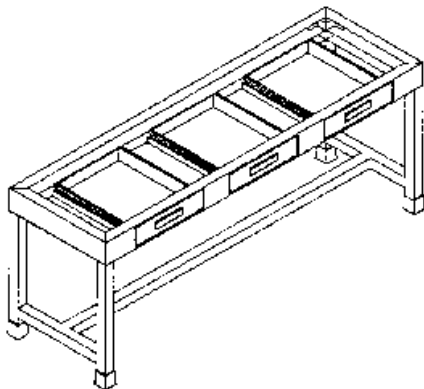

22" DEEP

UT297222-003

28" DEEP

UT297228-003

22" DEEP

UT357222-003

28" DEEP

UT357228-003

NOTE: UTILITY TABLES DO NOT INCLUDE COUNTER TOPS.

NOTE: When ordering units with configurations that are non-standard, drawings must accompany order.

ACCESSORIES

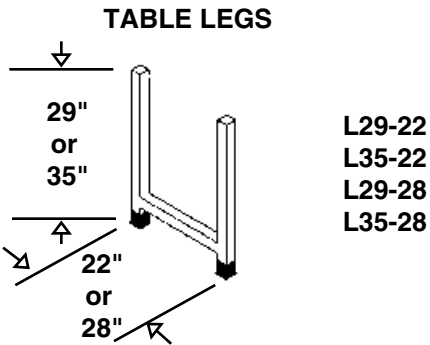

L29-22
L35-22
L29-28
L35-28

SINGLE LEG



SL-29
SL-35

SINGLE LEG WITH PLATE



SL-29P
SL-35P

END PEDESTAL

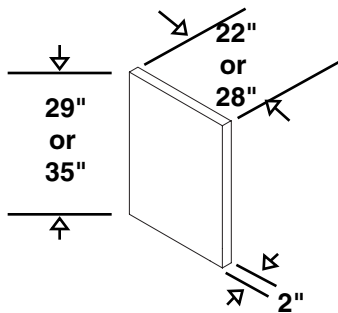

EP2902-22
EP3502-22
EP2902-28
EP3502-28

WALL CASE FRONT FILLER

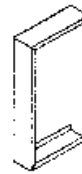

Specify (W)
(width)
WCCFF24-W
WCCFF30-W
WCCFF36-W
WCCFF48-W

WALL CASE CORNER FILLER

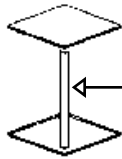

WCCF24-W
WCCF30-W
WCCF36-W
WCCF48-W
Angle is 1"

REAGENT SHELF UPRIGHT

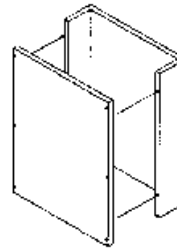

RSU1812
(18"Hx12"Dx2"W)

Note: Special heights & options available upon request. Drawings and dimensions must accompany order.

WALL - FLOOR CASE SHELF

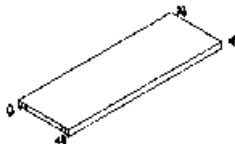

SLOPE TOP WITH END CAPS

PART NUMBERS

PART NUMBERS	
WALL	FLOOR
WS1813	FS1816
WS2413	FS2416
WS3013	FS3016
WS3613	FS3616
WS4213	FS4216
WS4813	FS4816
WS1816	FS1821
WS2416	FS2421
WS3016	FS3021
WS3616	FS3621
WS4216	FS4221
WS4816	FS4821

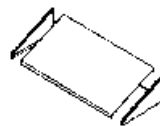

ST13-18	ST21-18
ST13-24	ST21-24
ST13-30	ST21-30
ST13-36	ST21-36
ST13-42	ST21-42
ST13-48	ST21-48
ST16-18	
ST16-24	
ST16-30	
ST16-36	
ST16-42	
ST16-48	

NOTE: When ordering units with configurations that are non-standard, drawings must accompany order.

ACCESSORIES

KNEE SPACE PANELS

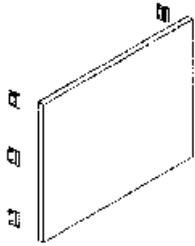

For use in sit down situation with apron

24" HIGH

KSP 2424
KSP 2430
KSP 2436
KSP 2442
KSP 2448
KSP 2454
KSP 2460
KSP 2466
KSP 2472

For use in standing situation with apron, or sit down without apron

29" HIGH

KSP 2924
KSP 2930
KSP 2936
KSP 2942
KSP 2948
KSP 2954
KSP 2960
KSP 2966
KSP 2972

For use in standing situation without apron

35" HIGH

KSP 3524
KSP 3530
KSP 3536
KSP 3542
KSP 3548
KSP 3554
KSP 3560
KSP 3566
KSP 3572

FILL PANELS

All base cabinet fillers are 35" high. Fillers for 29" high (low base) cabinets will need to be trimmed by the installer. Other sizes available upon request.

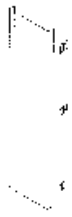

C-FILLER

CF35-8
CF35-14

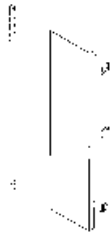

L-FILLER

LF35-1
LF35-7
LF35-11

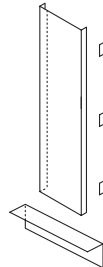

C-FRONT FILLER

FFC35-8
FFC35-14

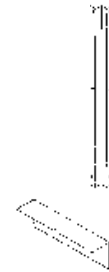

CORNER FILLER

ICF35-1
ICF35-2
ICF35-4

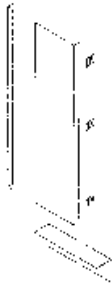

L-FRONT FILLER

FFL35-8
FFL35-14

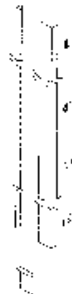

FLOOR CASE FILLER

FFL84-2
FFL84-8



TOE SPACE FILLER

B-455

* Last number(s) in filler designation indicates width of filler assembly.

Represented By:



BMC METAL-ARC

P.O. Box 4089
Muskegon, MI 49444
Telephone: (231) 733-1206
FAX: (231) 733-2116
Web page: www.bmclab.com
E-mail: bmc@bmclab.com

© BMC Metal-Arc
2002 Printed in the U.S.A.